

# Plated.

CHRIS LOCK

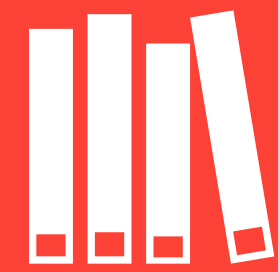

**PLATTERN**

**Plated.**

OUR APPLICATION

# The Current State

**September 2015**

**The Current State**

**Where We're Going**



# September 2015

Rails + JS Jungle

# September 2015

Rails + jQuery + Global Namespace

**September 2015**

**The Current State**

**Where We're Going**



Server-Side Rendering

Minimal JS Footprint

Deferred Loading

ES6+



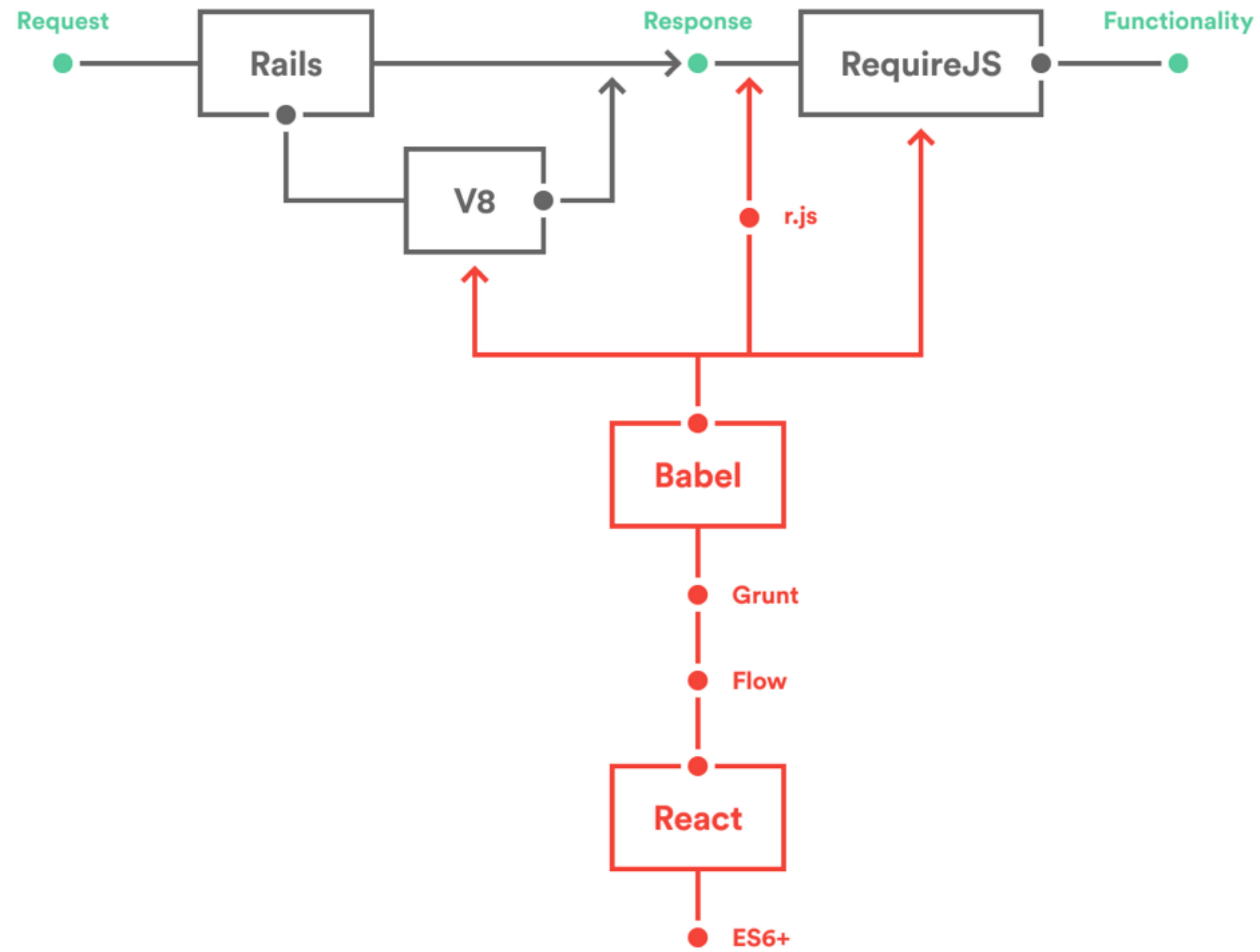

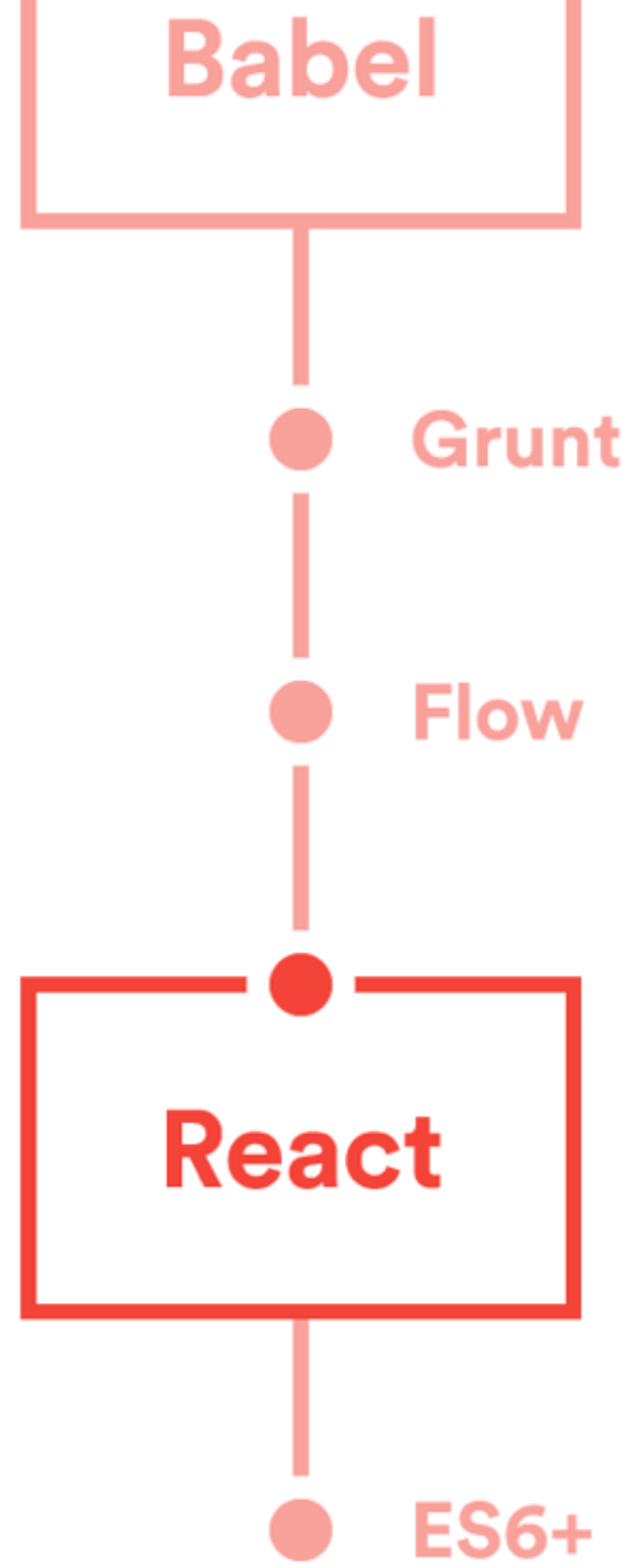

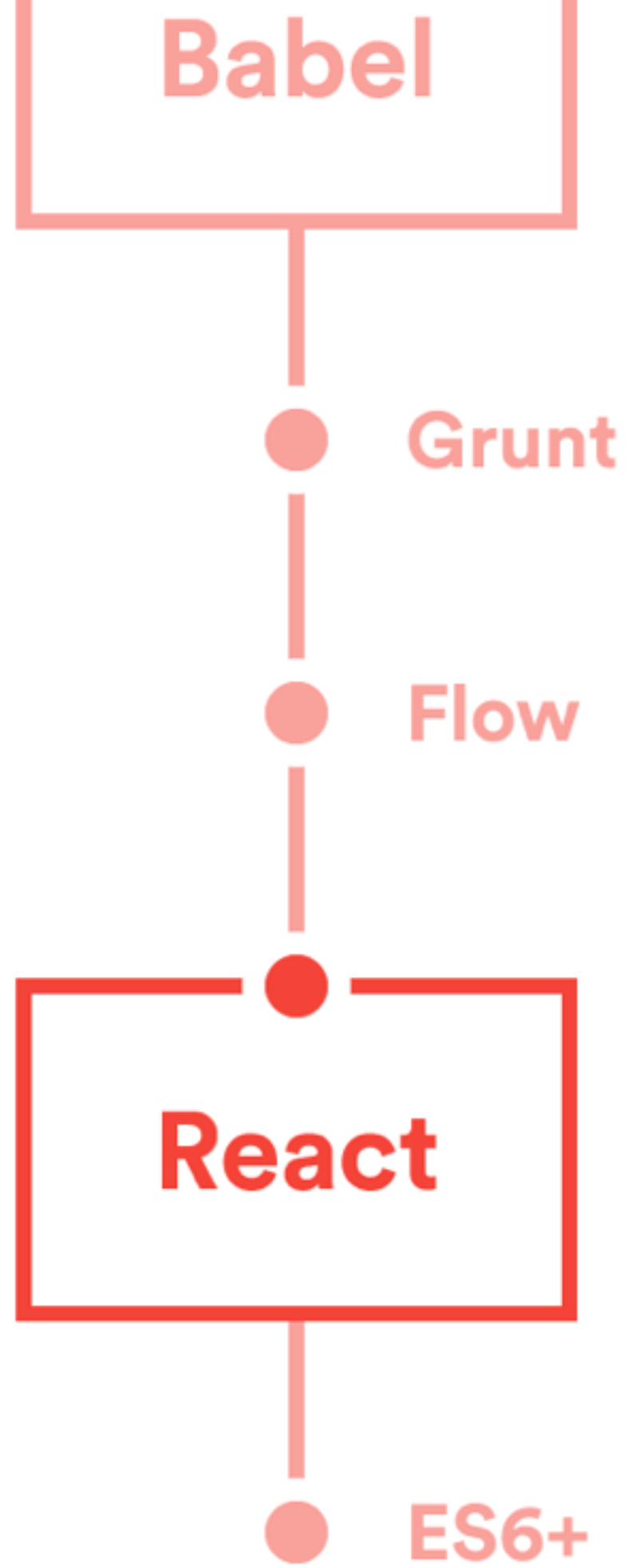

**Choosing a technology  
that our team was  
excited about**

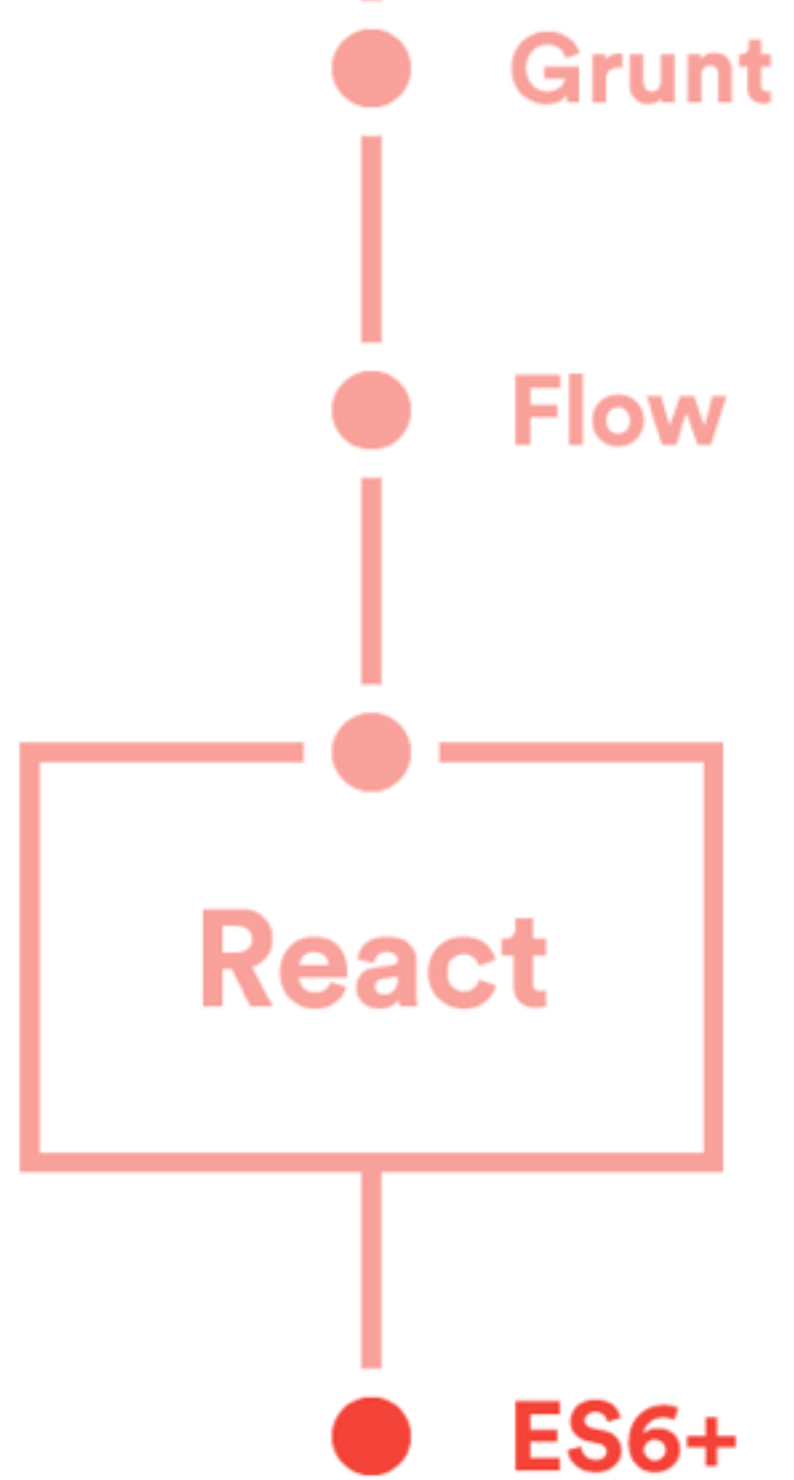

```
function Polygon(x, y) {  
  this.x = x;  
  this.y = y;  
  this.vertices = [];  
}
```

```
Polygon.prototype = {  
  addVertex: function(v) {  
    this.vertices.push(v);  
  }  
};
```

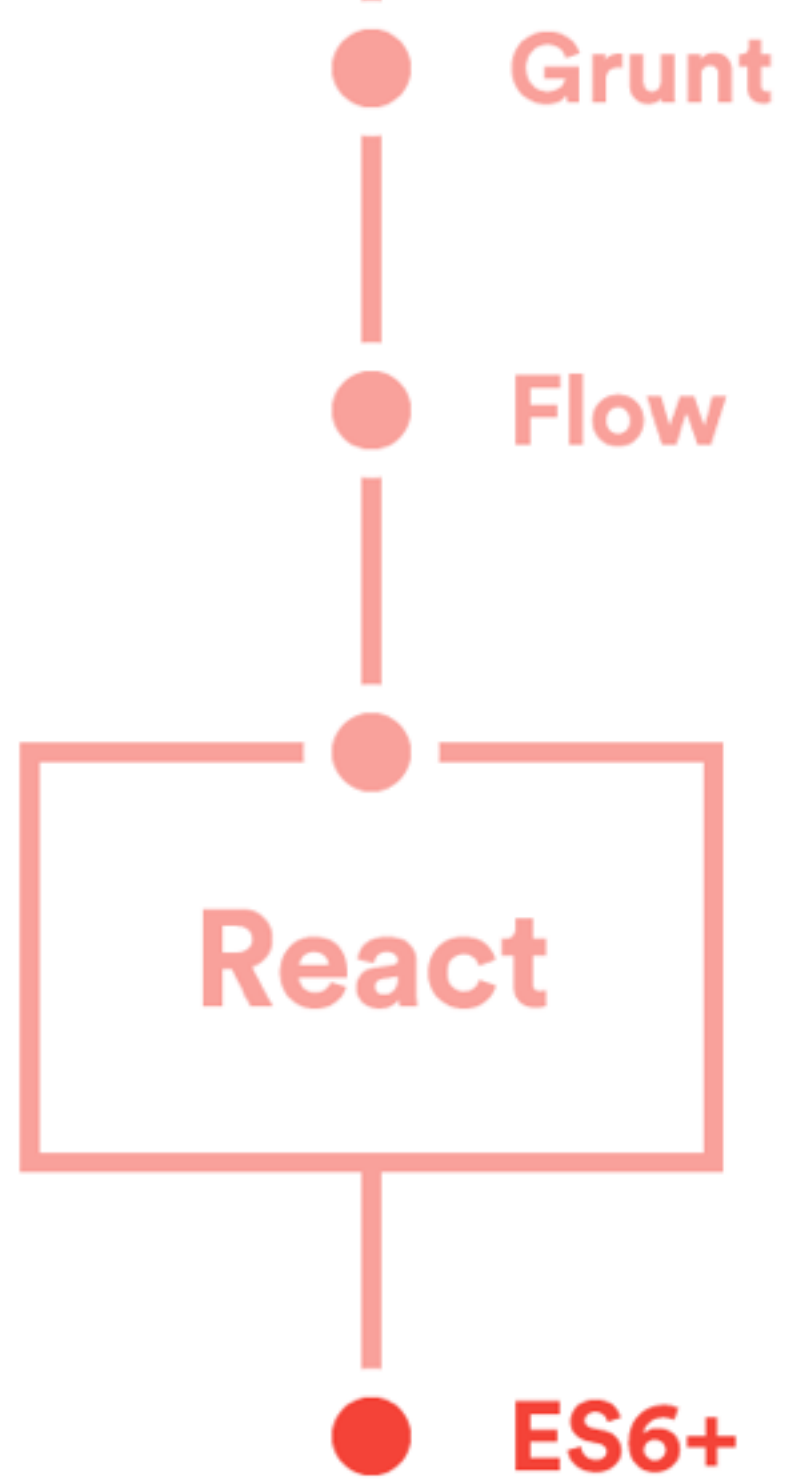

```
class Polygon {  
  vertices = [];  
  
  constructor(x, y) {  
    this.x = x;  
    this.y = y;  
  }  
  
  addVertex(v) {  
    this.vertices.push(v);  
  }  
}
```

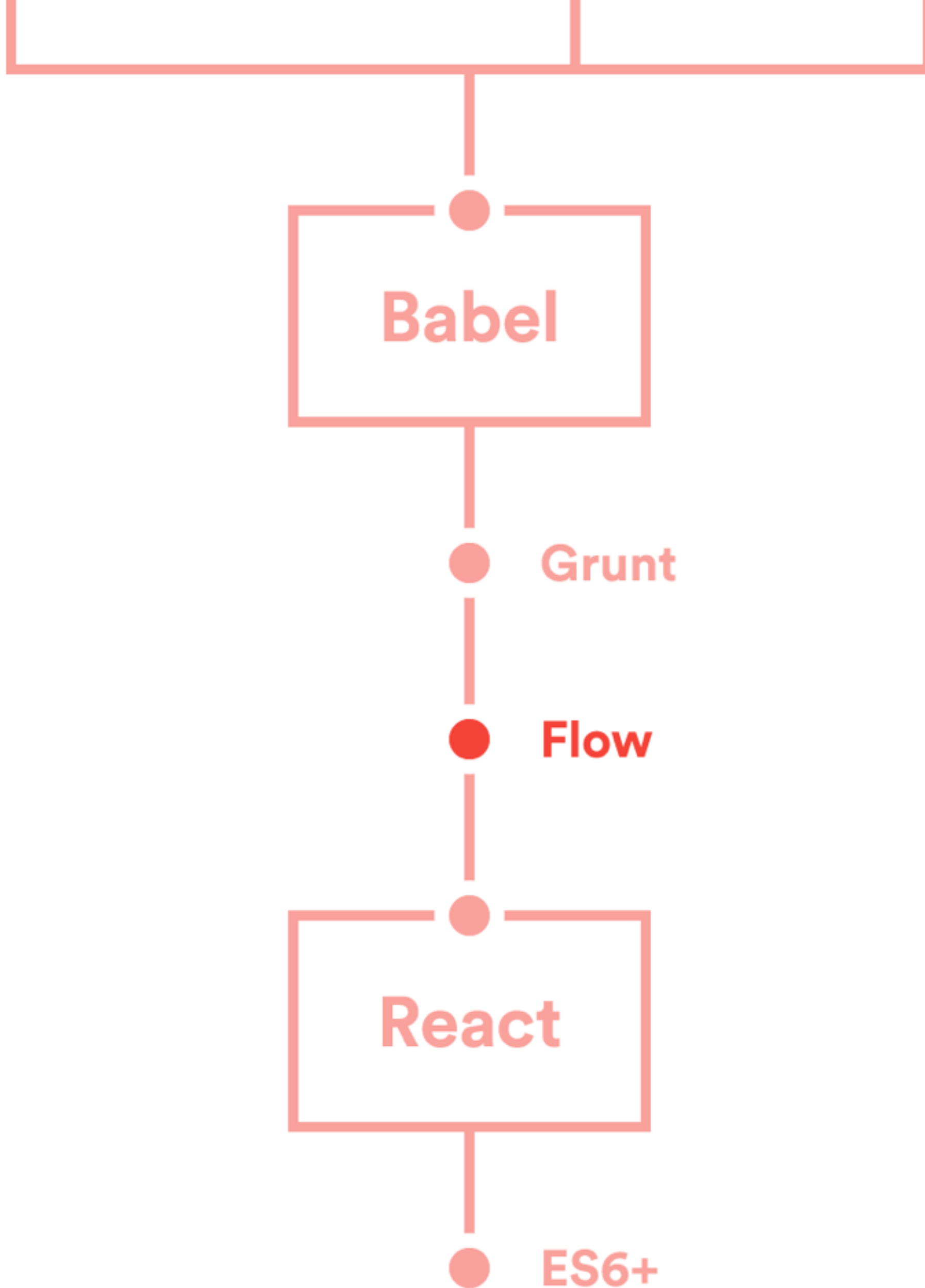

```
class Polygon {  
  x: number;  
  y: number;  
  vertices: Array<Point> = [];  
  
  constructor(x: number, y: number) {  
    this.x = x;  
    this.y = y;  
  }  
  
  addVertex(v: Point): void {  
    this.vertices.push(v);  
  }  
}
```

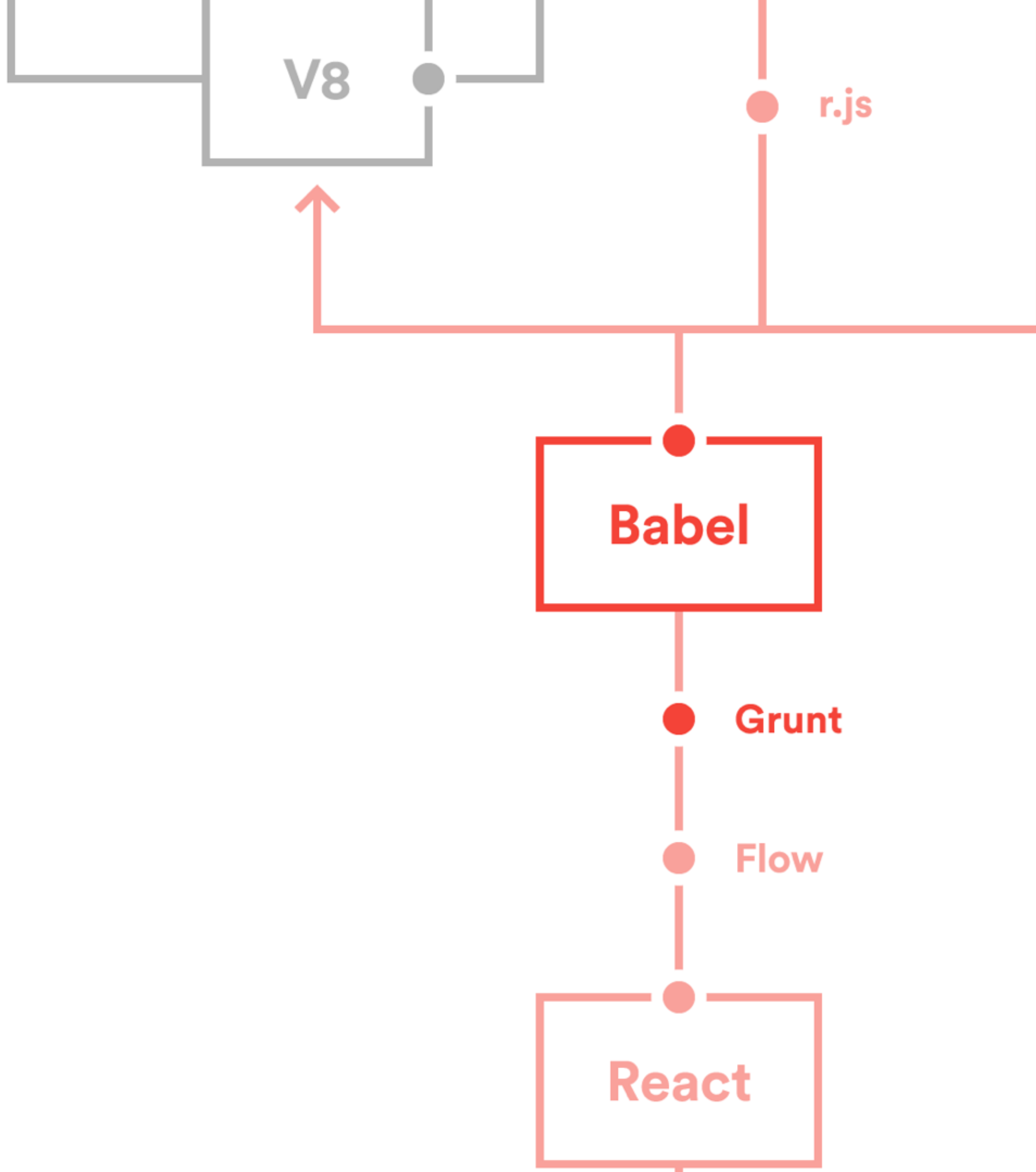

INTEGRATION

# Features vs Frameworks



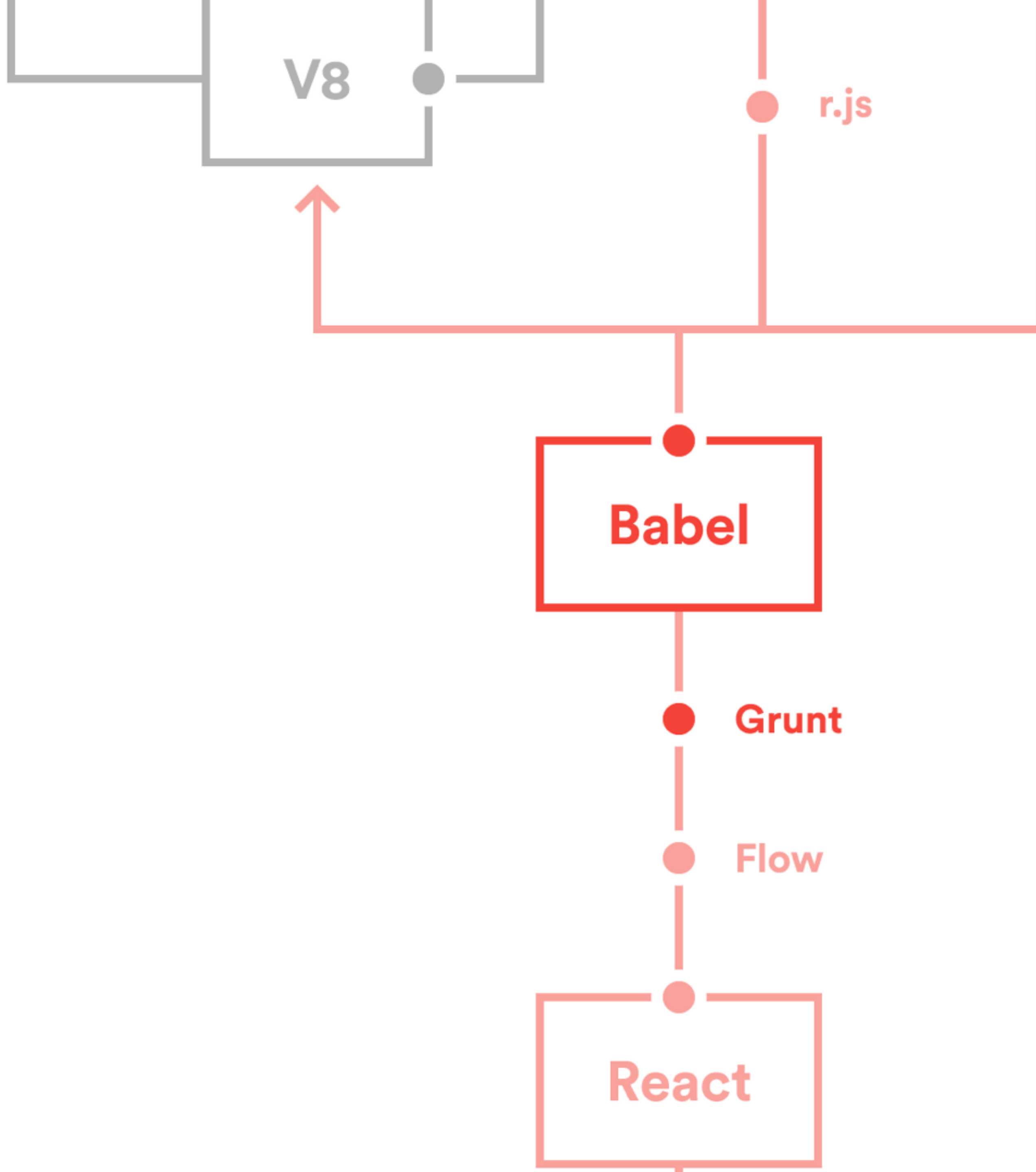

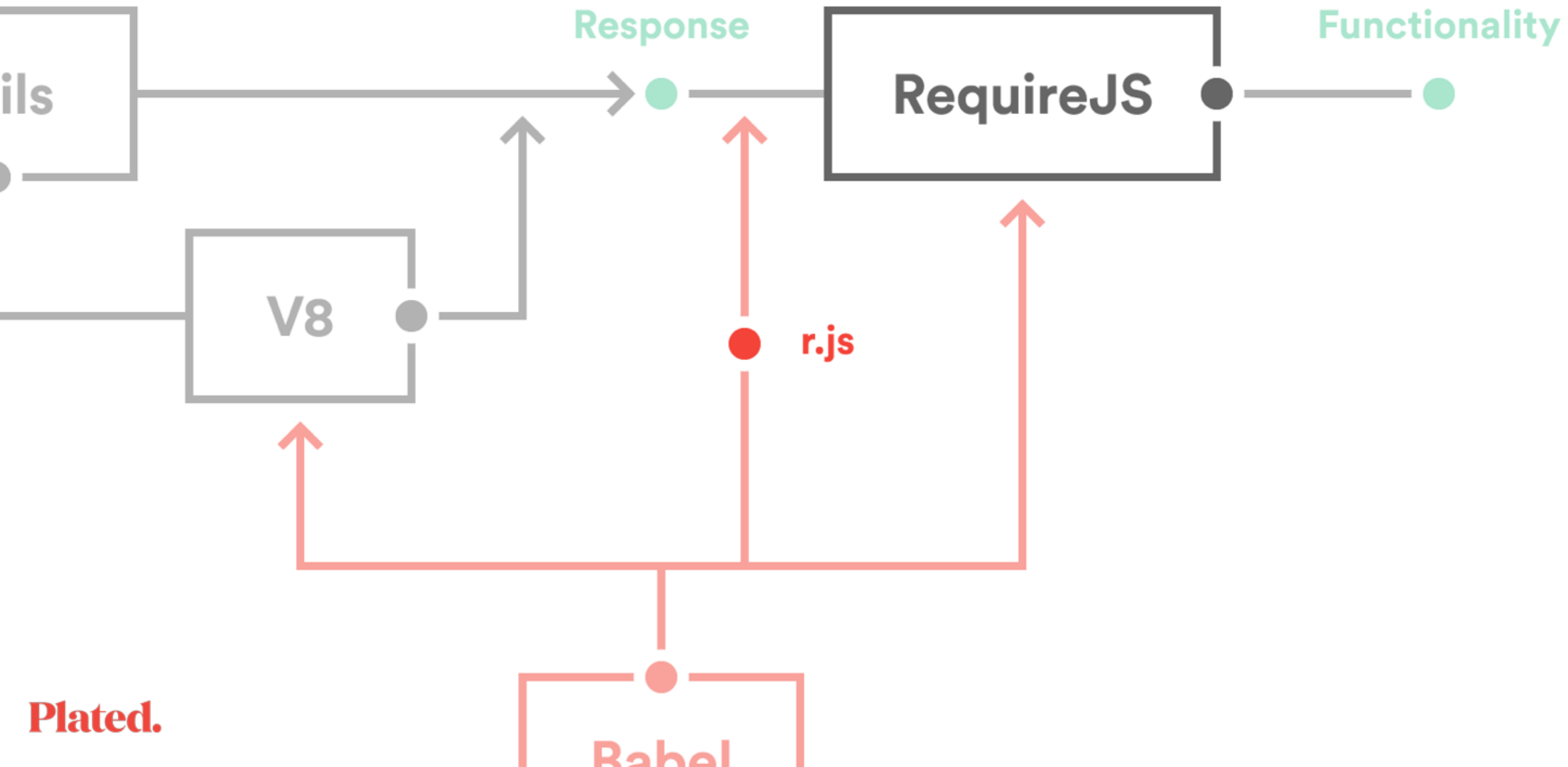

Request



Rails



Response



R



V8



r.js



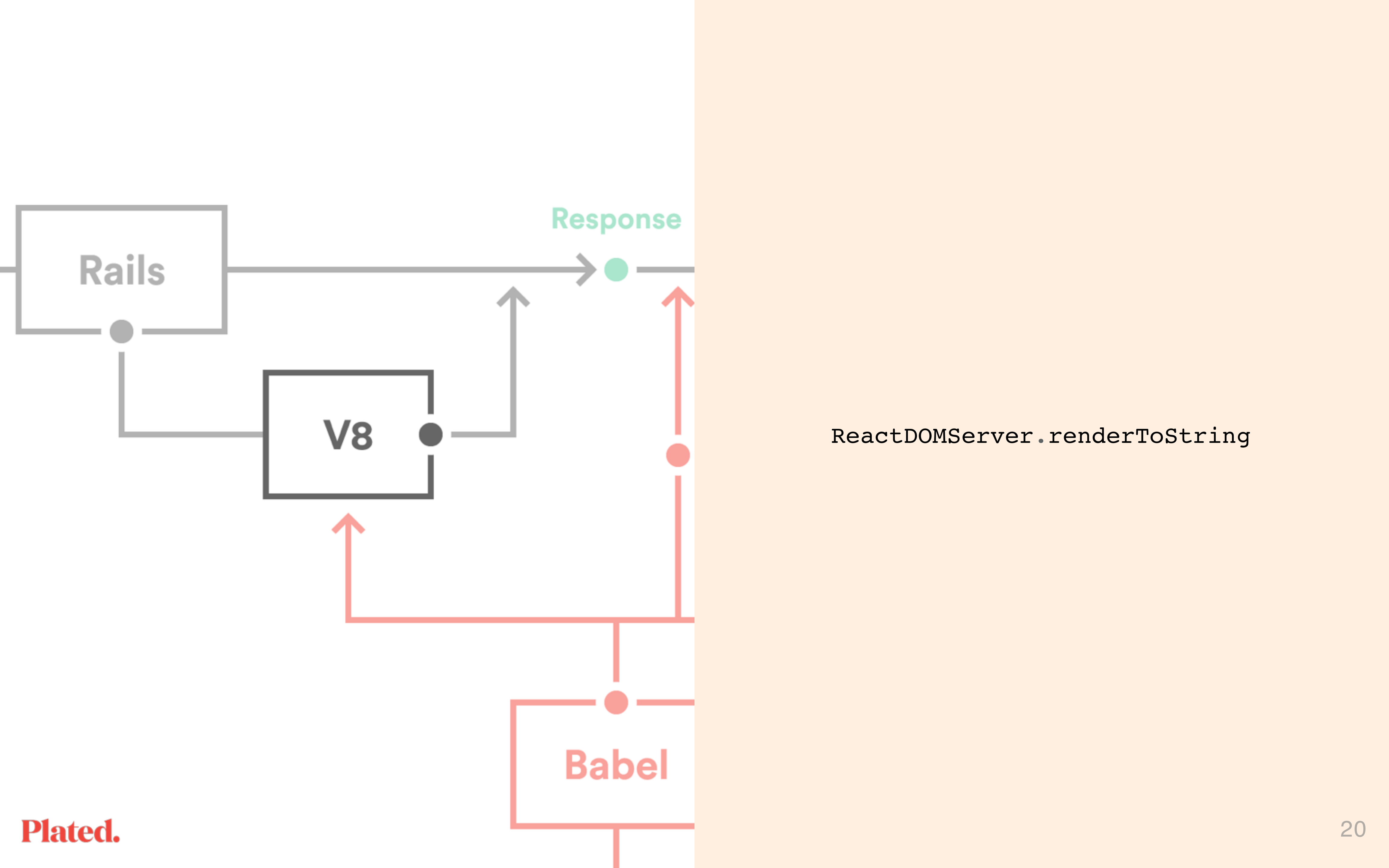

WTF IS

# Unidirectional Data Flow



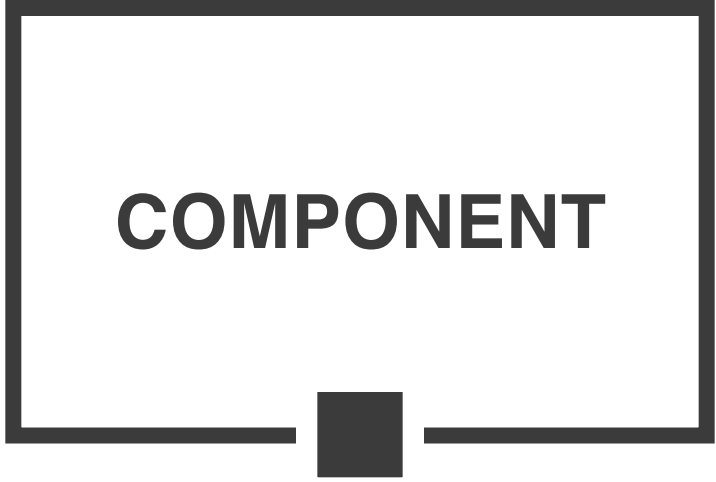
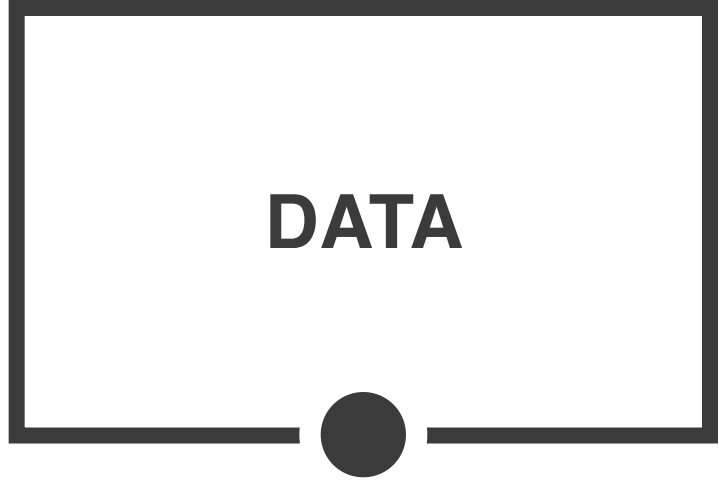





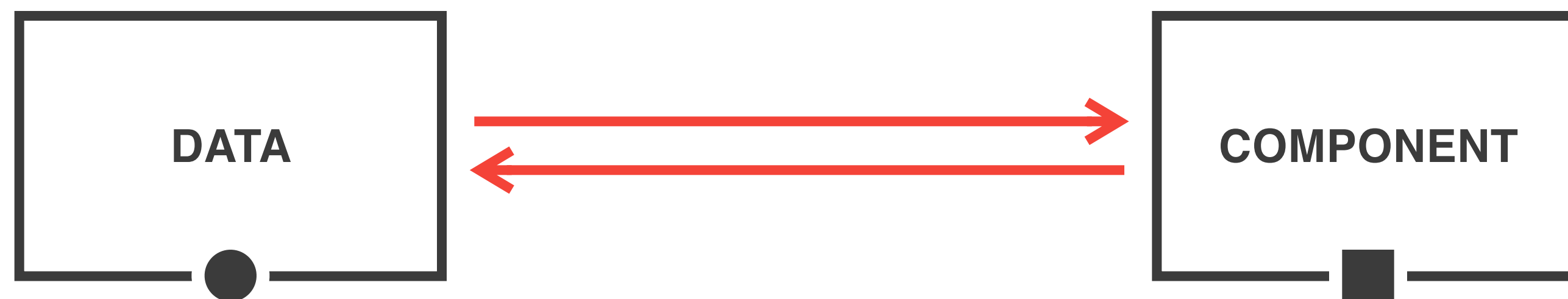

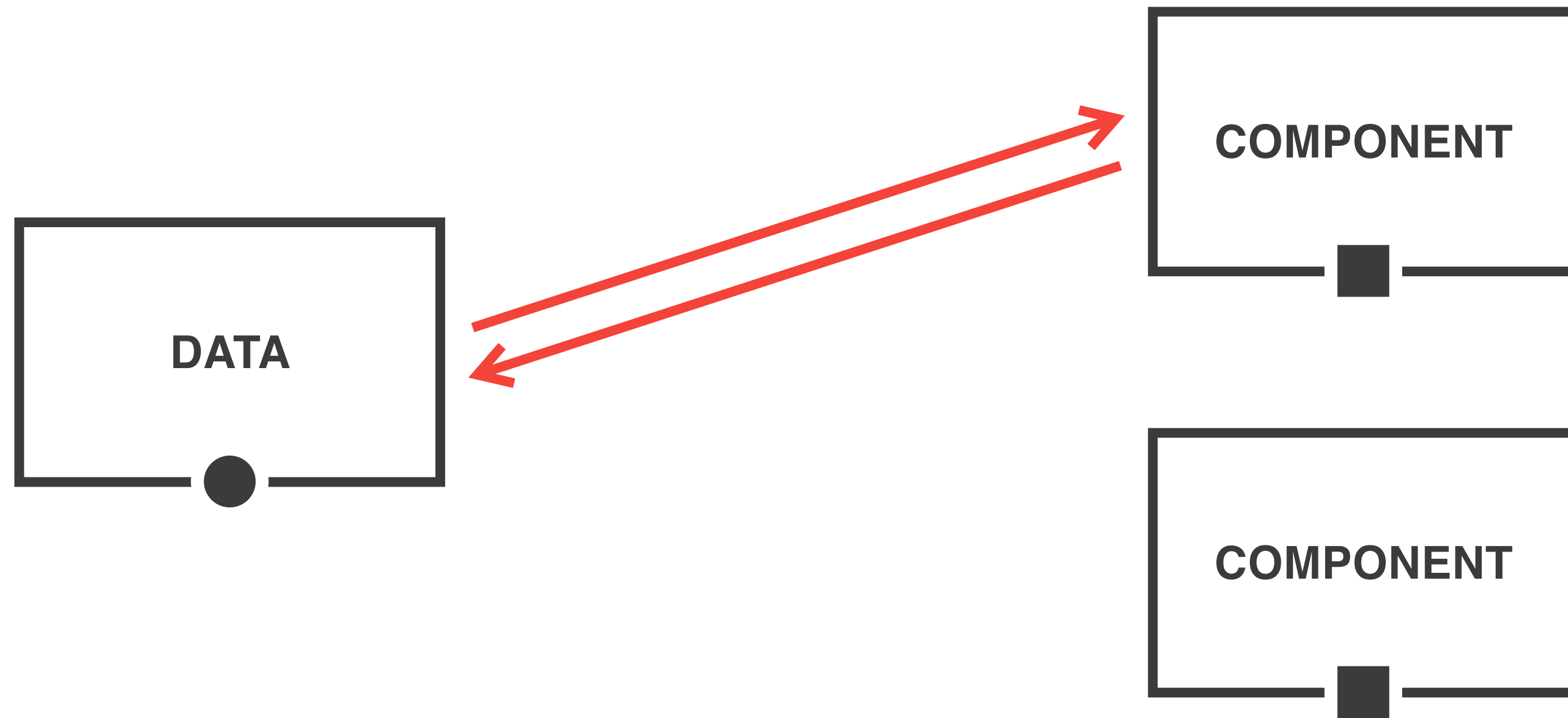

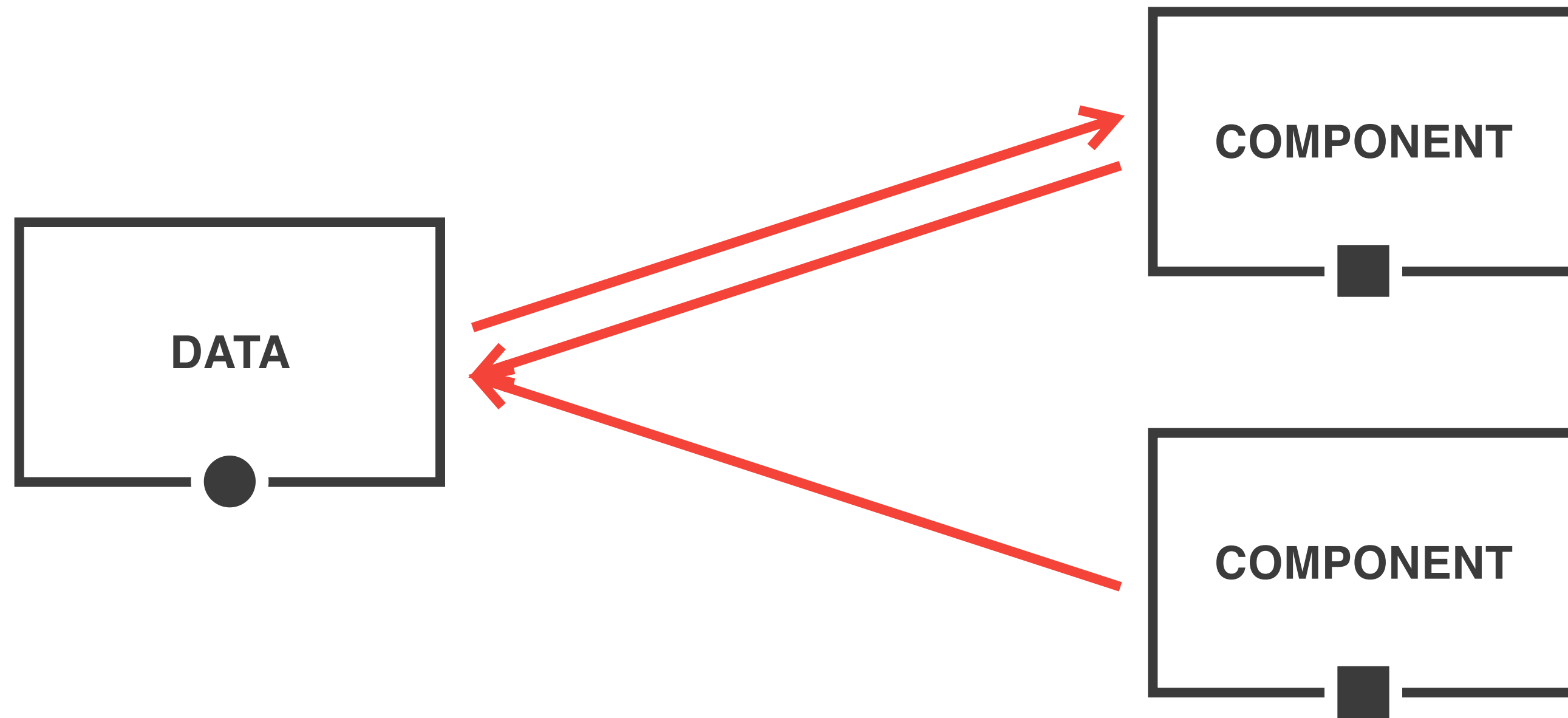

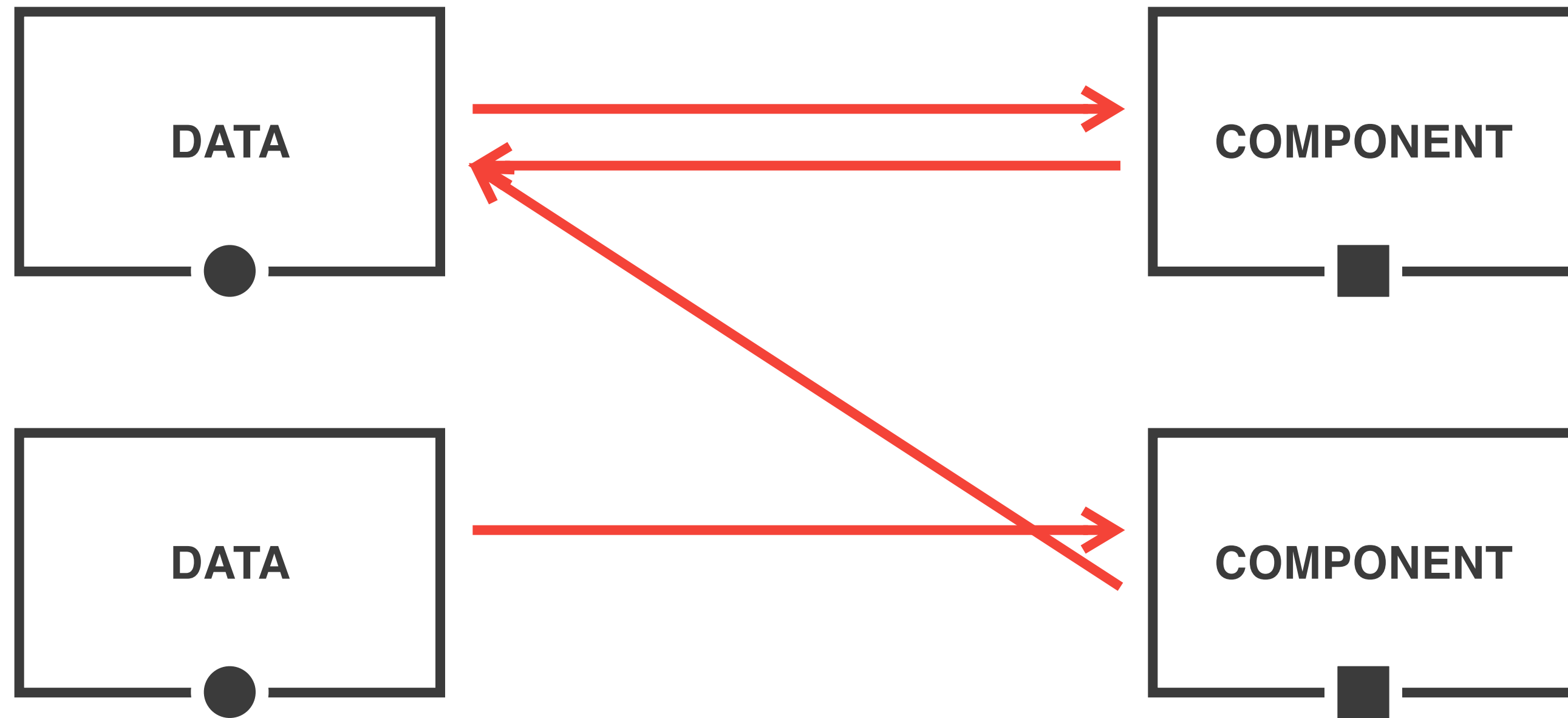

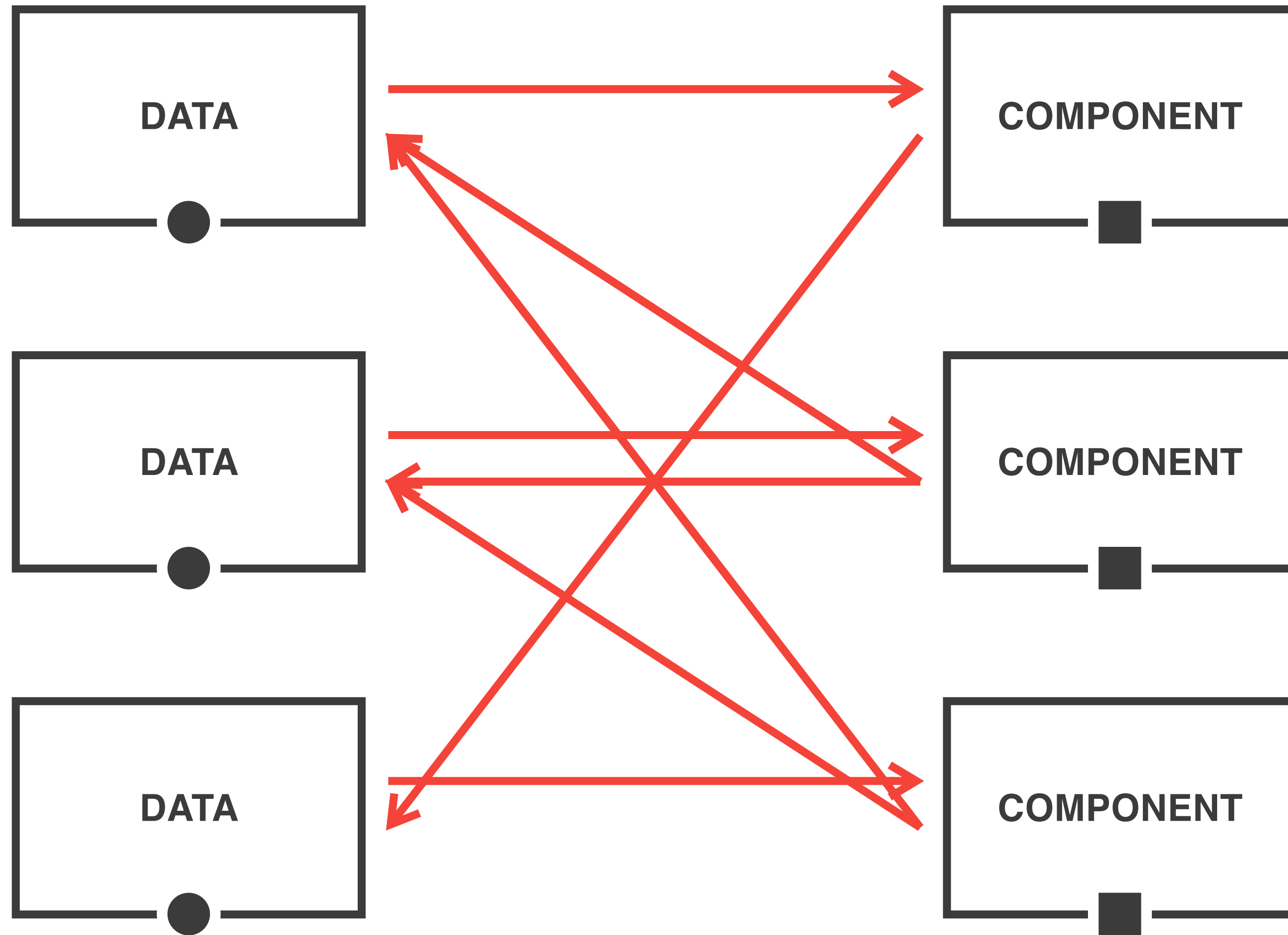

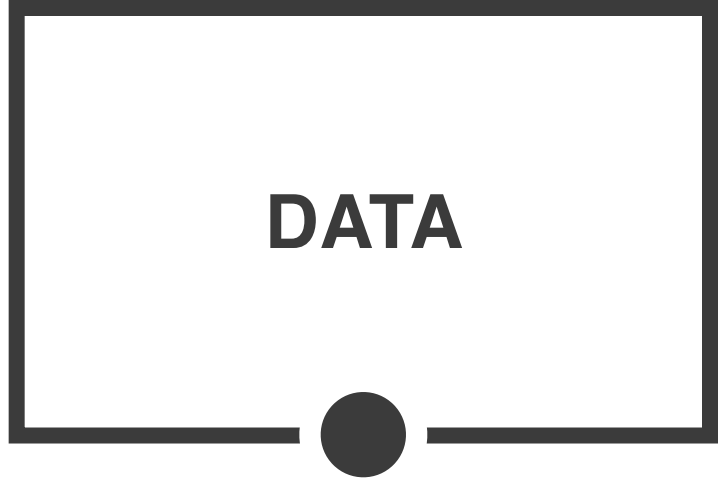

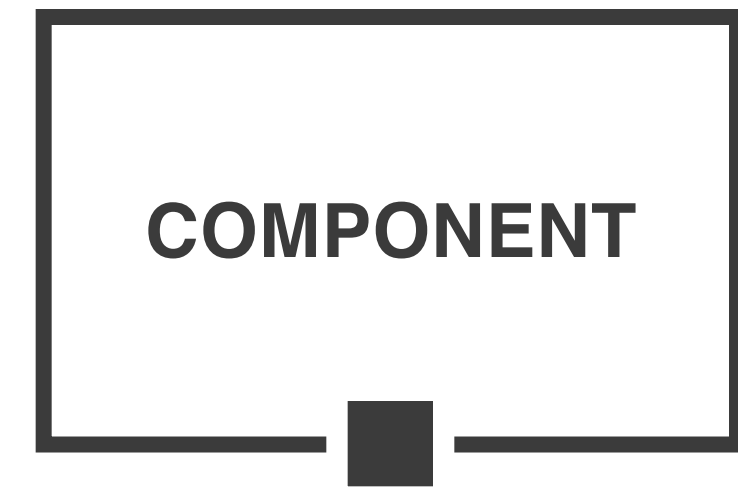
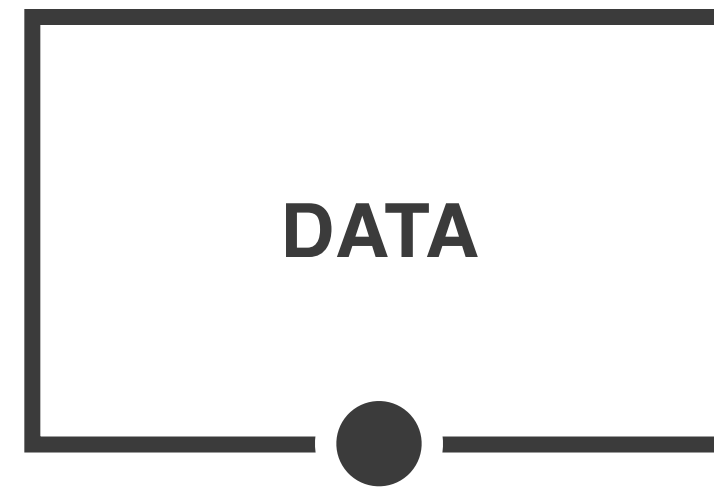
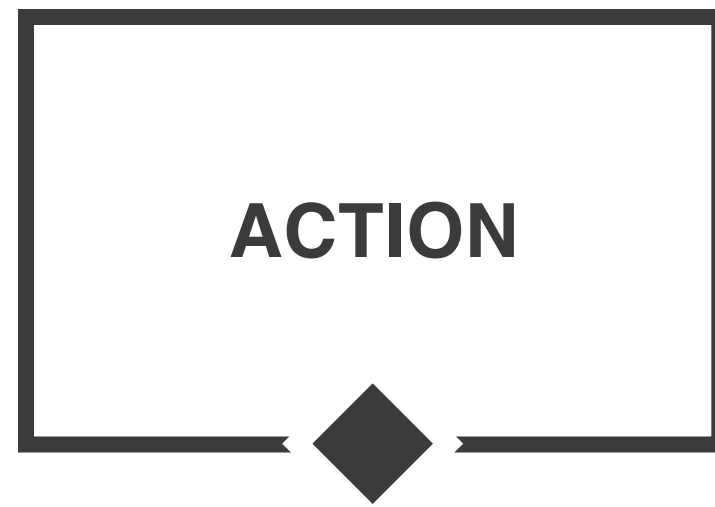

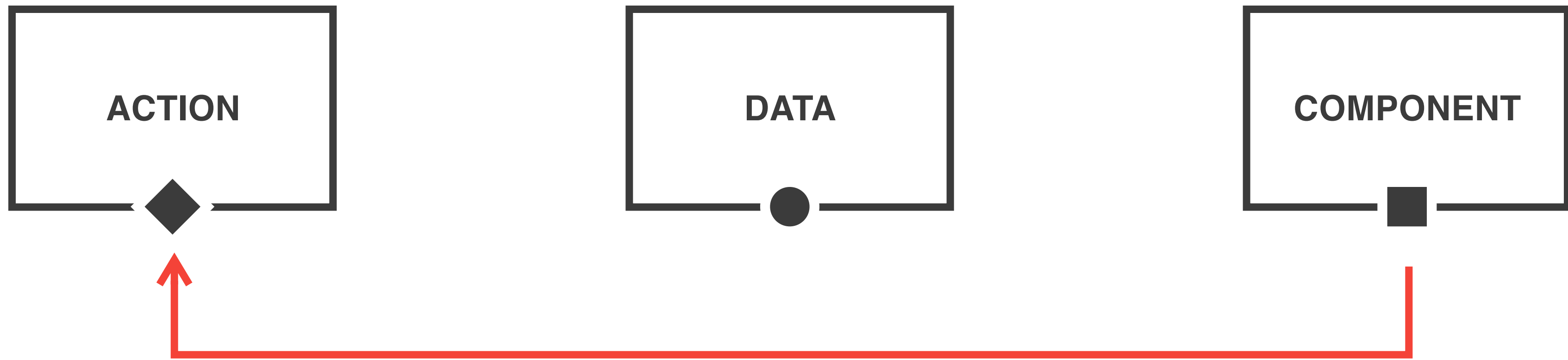



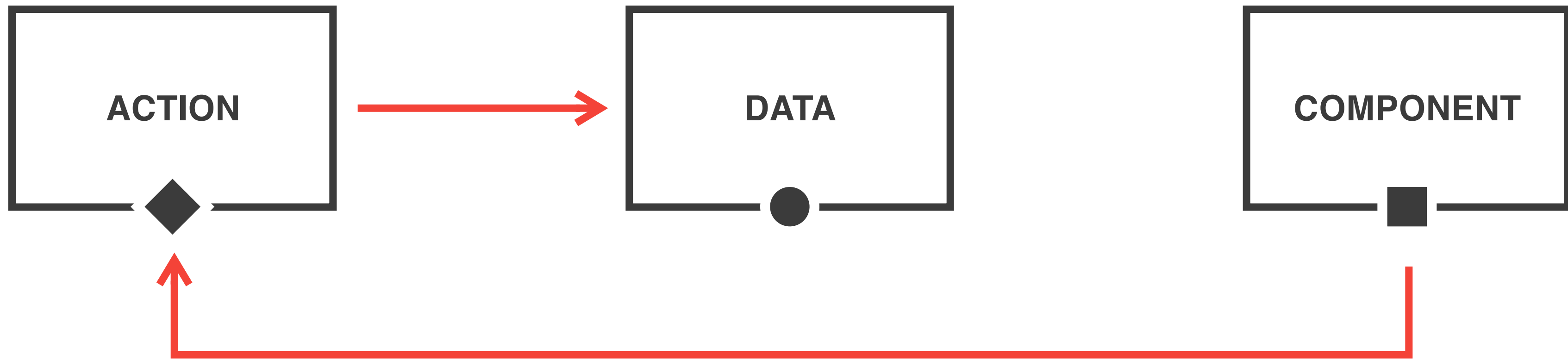

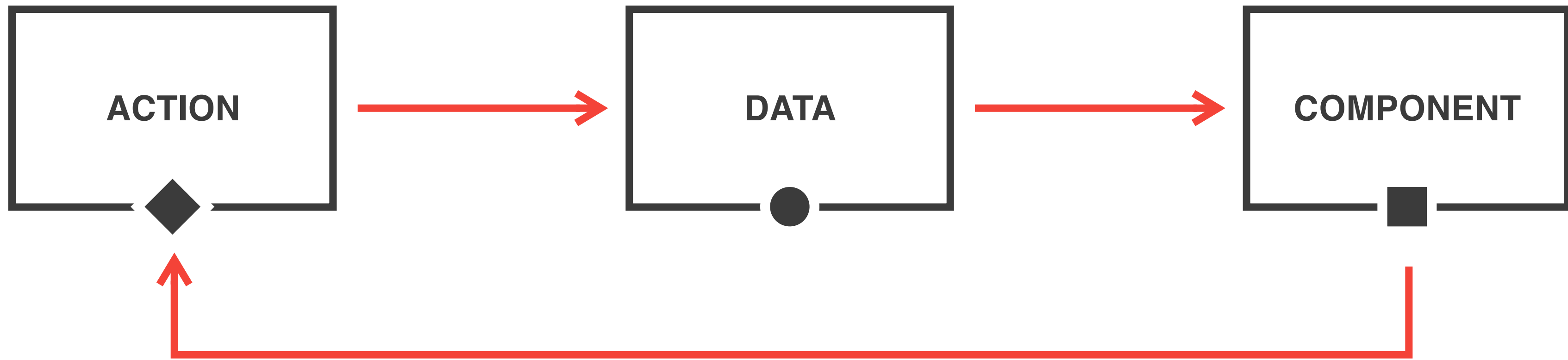

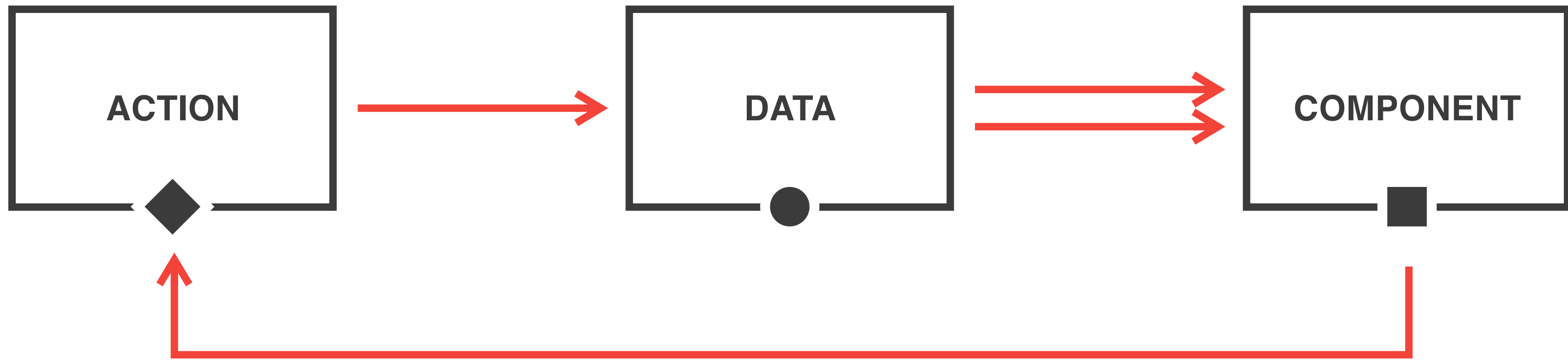

MOVING TOWARD

# Stateful Data

**Plated.**

**[PLATED.COM/CAREERS](https://plated.com/careers)**